



Power Door Products
(914) 698-5083
www.PowerDoorProducts.com

ALL-O-MATIC®



USER'S MANUAL

POWER INVERTER

APS1000-12 & APS2000-24

Table of Contents

Important Safety Information	1
General Safety Precautions.	1
Precautions When Working With Batteries	1
General Informtion.	2
Application	3
Features	3
Basis System Architecture	4
Product Overview	4
Installation	5
Unpacking and Inspection	5
Preparation	6
Mounting The Unit	6
Battery Connection	7
AC Input/Output Connection	9
Electrical Performance	11
LCD Display Icons	14
Relay connections for gate operator auto open/close functions. . . .	15
Operating Mode Description	16
Warning Code/Audible Alarm	19
Troubleshooting Guide	20

Important Safety Information



! wb Lb D^s

This manual contains important instructions for APS1000-12 & APS2000-24 models that shall be followed during installation and maintenance of the inverters.

General Safety Precautions

1. Before installing and using the inverter/charger, read all instructions and cautionary markings on the inverter/charger and all appropriate sections of this guide. Be sure to read all instructions and cautionary markings for any equipment attached to this unit.
2. Install this unit away from direct sun light and where is not exposed to water sprinklers.
3. To reduce risk of fire hazard, do not cover or obstruct the ventilation openings. Do not install the inverter/charger in a zero-clearance compartment. Otherwise overheating may occur.\
4. Use only attachments recommended or sold by the manufacturer. Doing otherwise may result in a risk of fire, electric shock, or injury to persons.
5. To avoid a risk of fire and electric shock, make sure that existing wiring is in good condition and that wire is not undersized. Do not connect the inverter/charger with damaged or substandard wiring.
6. Do not operate the inverter/charger if it has received a sharp blow, been dropped, or otherwise damaged in any way. If the inverter/charger is damaged, read the warranty section.
7. Do not disassemble the inverter/charger. It contains no user-serviceable parts. See warranty for instructions on obtaining service. Attempting to service the inverter/charger yourself may result in a risk of electrical shock or fire. Internal capacitors remain charged after all power is disconnected.
8. The inverter contains more than one live circuit (batteries and AC line). Power may be present at more than one source. To reduce the risk of electric shock, disconnect both AC and DC power from inverter/charger before attempting any maintenance or cleaning or working on any circuits connected to the inverter/charger. Turning off controls will not reduce this risk.
9. Use insulated tools to reduce the chance of short-circuits when installing or working with the inverter or the batteries.

Precautions When Working with Batteries

1. Make sure the batteries are well ventilated. Avoid blocking enclosure vents.
2. Never smoke or allow a spark or flame near the inverter or batteries.
3. Use caution to reduce the risk of dropping a metal tool on the batteries. It could spark or short circuit the battery or other electrical parts and could cause an explosion.
4. Remove all metal items, like rings, bracelets, and watches when working with lead-acid batteries. Lead-acid batteries produce a short circuit current high enough to weld metal to skin.
5. Make sure someone is close enough to aid should anything dangerous occur when you're working near a lead-acid battery.

6. Prepare enough fresh water and soap in case battery acid contacts skin, clothing or eyes.
7. Wear complete eye protection and clothing protection. Avoid touching your eyes while working near batteries.
8. If battery acid contacts skin or clothing, wash immediately with soap and water. If acid enters your eyes, immediately flood in cold water and get medical attention immediately.
9. If you need to remove a battery, always remove the ground terminal from the battery first. Make sure all accessories are off so you don't cause a spark.
10. Always use identical types of batteries.
11. Never install old or untested batteries. Check each battery's date code label to ensure age and type.
12. Batteries are temperature sensitive. For optimal performance, they should be installed in a stable temperature environment.
13. Always recycle old batteries. Contact your local recycling center for proper disposal information.

General Information

Thank you for purchasing the APS inverter series.

The inverter is a combination of an inverter, charger.

It is packed with unique features and it is one of the most advanced inverter/charger in the market today.

The inverter features an AC bypass circuit, powering your gate operators and access controls or any appliance from the utility power or generator power while charging the battery. When utility power fails, the battery backup system keeps your equipment powered until utility power is restored. Internal protection circuits prevent over-discharging the batteries by shutting down inverter when a low battery condition occurs. When utility or generator power is restored, the inverter transfer to the AC source and recharges the batteries.

The series inverter can also serve as a central hub of renewable energy system. Set the series inverter to battery priority mode to designate it to inverter-preferred UPS configuration. In this configuration, the load power is normally provided by the inverter. However, if the inverter output is interrupted, an internal transfer switch automatically transfers the load from the inverter to commercial utility power. The transfer time between inverter and line is short(6ms typically), and such transfers are normally not detected by even highly sensitive loads. Upon restoration of battery capacity, the inverter will transfer back to inverter power (battery).

In the line priority mode, when utility power cuts off (or drops below acceptable range), the transfer relay is de-energized and the load is automatically transferred to inverter output.

Once the qualified utility power is restored, the relay is energized and the load is automatically reconnected to utility power.

It features power factor, sophisticated multi-stage charging and pure sine wave output with unprecedentedly high surge capability to meet demanding power needs of inductive loads without endangering the equipment.

The inverter is equipped with a powerful charger of up to 70Amp (depending on mode). The overload capacity is 125~150% of continuous output for up to 20 seconds to reliably support tools and equipment longer.

Another important feature is that the inverter can be easily customized to solar priority by DIP switch, this helps to extract maximum power from solar in renewable energy systems.

To get the most out of the power inverter, it must be installed, used and maintain properly.

Please read the instructions in the manual before installing.

Application

Gate operators, access control devices and accessories.

Power tools-circular saws, drills, grinders, sanders, buffers, weed and hedge trimmers, air compressors.

Office equipment such as computers, printers, monitors, facsimile machines, scanners. Household items, vacuum cleaners, fans, fluorescent and incandescent lights, shavers, sewing machines.

Kitchen appliances-coffe makers, blenders, ice makers, toasters.

Industrial equipment-metal halide lamp, high-pressure sodium lamp.

Home entertainment electronics-television, VCRs, video game consoles, stereos, musical instruments, satellite equipment.

Features

- Pure sine wave output
- AC/Battery priority Via function DIP switch
- Auto generator start. For gate operators Auto open relay.
- Max. AC charge current 35A
- Built-in pure copper transformer
- Low battery trip voltage 10.5V/11.0V setting
- Auto sense 50HZ/60HZ

Generator or Grid.

Battery

Basic System Architecture

The following illustration shows basic application for this inverter. It also includes following devices to have a complete running system:

Generator or Utility. Battery

Consult with your system integrator for other possible system architectures depending on your requirements.

This inverter can power all kinds of appliances in home or office environment, including motor-type appliances such as tube light, fan, refrigerator and air conditioner. Also **Gate Operators** and accessories.

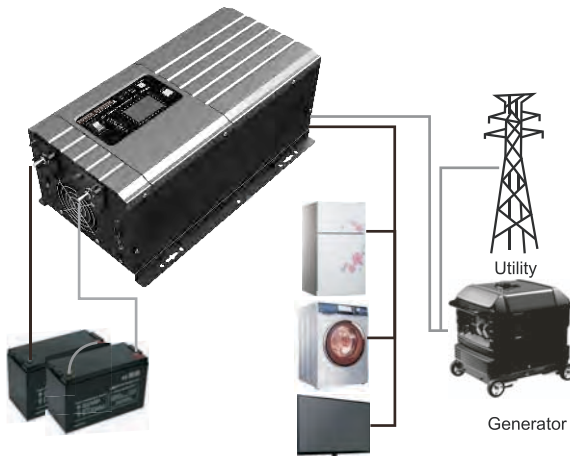

Battery pack

APS1000-12 includes two 35Ahr batteries

APS2000-24 includes two 50Ahr batteries

Home Appliances

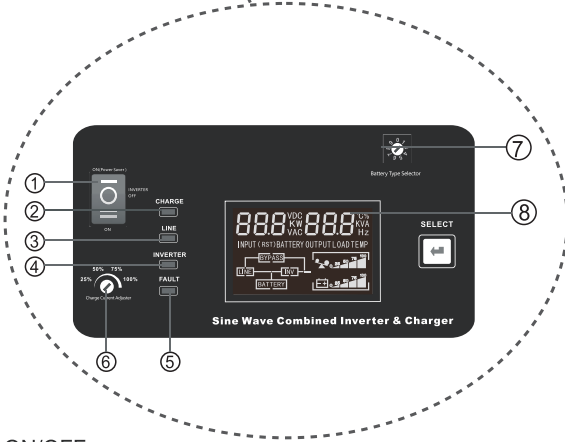
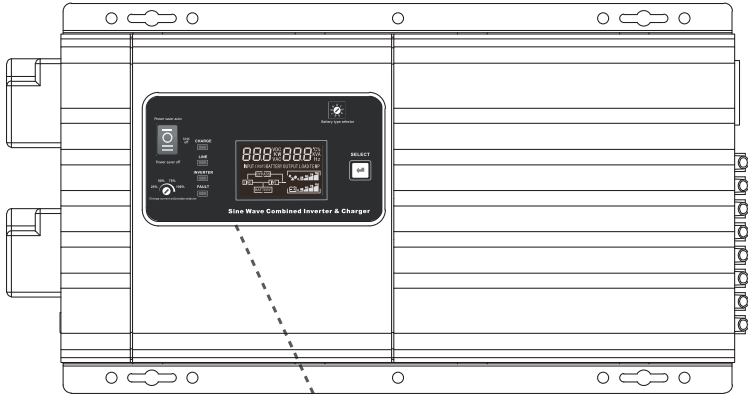

- 1. Switch ON/OFF
- 2. AC Charge
- 3. AC power on
- 4. Inverter mode
- 5. Fault
- 6. Charge Current Adjuster:25%,50%,75%,100%.
- 7. Battery Type Selector
- 8. LCD display

Audible Alarm

Battery Voltage Low	Inverter green LED Lighting, and the buzzer beep 0.5s every 5s.
Battery Voltage High	Inverter green LED Lighting, and the buzzer beep 0.5s every 1s, and Fault after 60s.
Inverter Mode Over-Load	110% < load < 125%, no audible alarm in 2 minutes, and Fault after 2 minutes. 125% < load < 150%, beeps 0.5s every 1s, and Fault after 20s. Load > 150%, beeps 0.5s every 1s, and Fault after 2s.
Over Temperature	Heat sink temp. $\geq 105^{\circ}\text{C}$, Over temp red LED Lighting, beeps 0.5s every 1s;

Switch	ON(Power Saver)	Power on with saver mode (power saver \leq 25W)
	INVERTER OFF	Power totally off (If there is AC power,inverter have charger function)
	ON	Power on without saver mode
Protection		
Over Temperature Protection	Heat sink temp. \geq 105°C, Fault (shutdown Output) after 30 seconds	
Back-Feed Protection	Yes	

IMPORTANT: When the inverter is used to power Gate Operators, switch must be in the **ON** position. Not the **ON (Power Saver)** position.

Connectors 8, 9 and 10 are extended to the inverter front panel for easy wiring.

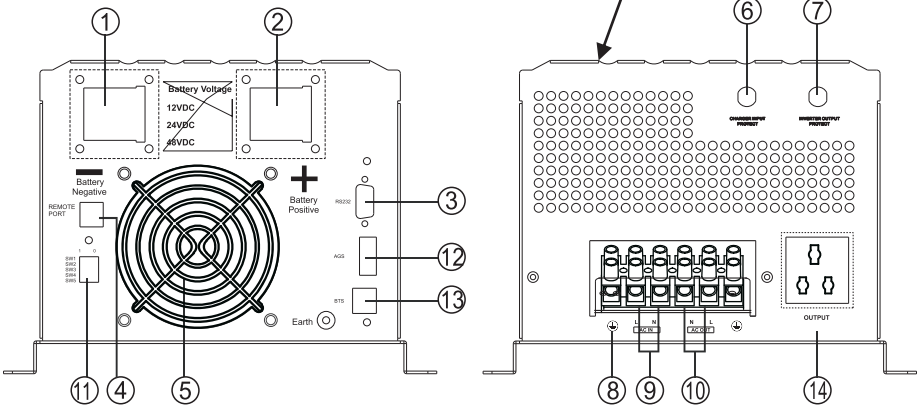

- 1. BAT -
- 2. BAT +
- 3. RS232 communication port
- 4. Remote port
- 5. FAN
- 6. AC input/Bypass breaker
- 7. AC output breaker

- 8. GND
- 9. AC input
- 10. AC output
- 11. Function Switch(SW1~SW5)
- 12. AGS
- 13. BTS
- 14. AC Output 10A(MAX)

INSTALLATION

Unpacking and Inspection

Before installation, please inspect the unit. Be sure that nothing inside is damaged. You should see the following items inside the main enclosure of the APS series inverters:

- Main inverter Unit
- Two Batteries
 - 35Ahr for APS1000-12
 - 50Ahr for APS2000-24
- Battery breaker on the left side inside enclosure
- AC Input/Output and relay connector on inverter front panel

Mounting the unit

Consider the following before selecting where to install the unit:

- Do not install the inverter on flammable construction materials.
- Mount on a solid surface.
- Install the inverter at eye level in order to read the LCD display clearly.
- For proper air circulation to dissipate heat, leave at least 3" gap above, below and sides of the inverter enclosure.
- The ambient temperature should be between 0°F and 105°F to ensure optimal operation.
- The recommended installation position is to be against the wall horizontally.

SUITABLE FOR MOUNTING ON CONCRETE OR OTHER NON-COMBUSTIBLE SURFACE ONLY.

Install the unit using 4 screws on four mounting holes

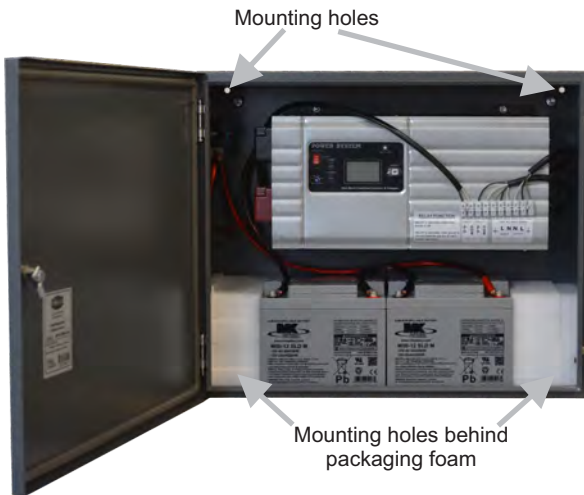

Battery Connection

CAUTION: For safety and regulation compliance, it's requested to install a separate DC over-current protector between battery and inverter. **DO NOT** bypass the over-current breaker that's installed between inverter and batteries. Doing so, will increase the risk of fire and possible harm to persons.

DC Wiring Recommendation

It is recommended the battery bank be kept as close as possible to the inverter. the following is the recommended wiring options for 3 feet long cable.

APS series inverters use 4AWG cable that meet or exceed this requirement. If there is a need to replace the battery cables, you must use the proper size to handle the power. If Batteries need to be moved outside the inverter enclosure and need to extend the cable, also increase the wire gauge thickness.

Model	Battery Voltage	Wire gage/Min	Model	Battery Voltage	Wire gage/Min	
		0-3 feet			0-3 feet	
1000W	12VDC	1*4AWG	2000W	24VDC	1*4AWG	

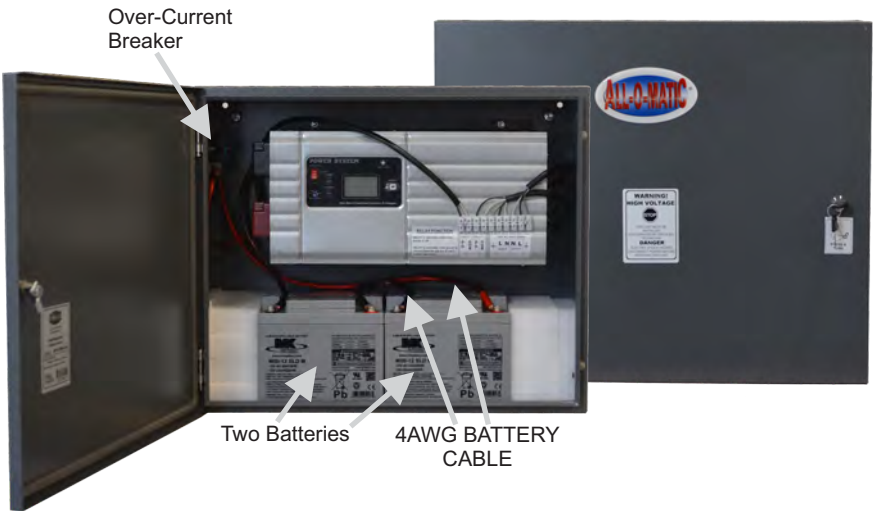

One cable is always best, but cable is just copper and copper is what's required, so it does not matter if you use one cable or 10 cables as long as the square are adds up. Performance of any product will be improved by thicker cable and shorter runs, so it is recommended to keep the cables as short as possible.

Please follow steps below in case battery cables need to be replaced:

1. Install battery ring terminals on recommended cable and terminal size.
2. Connect battery pack as unit requires. APS1000-12 must have batteries connected in parallel, and the APS2000-24 in series.

NOTE: Please only use Sealed Lead Acid or Sealed GEL/AGM Lead-Acid Batteries.

3. Connect ring terminals of battery cable into inverter battery connector and make sure bolts are tightened. Make sure polarity is correct at both ends of the cable (battery terminals and inverter connectors) and that ring terminals are tightly screwed to battery terminals.

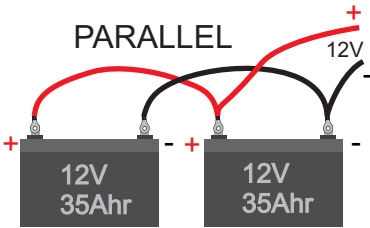

APS1000-12 Main battery bank, 12VDC.
(35Ahr **included**) wired in parallel.

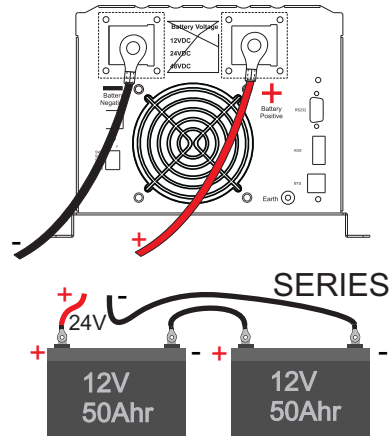

APS2000-24 Main battery bank, 24VDC.
(50Ahr **included**) wired in series.



WARNING: Shock Hazard

Installation must be performed with care due to high battery voltage in series.



CAUTION!! Do not place anything between the flat part of the inverter terminal and the ring terminal. Otherwise, overheating may occur.

CAUTION!! Do not apply anti-oxidant substance on the terminals before terminals are connected tightly.

CAUTION!! Before making the final DC connection or closing DC breaker/disconnector, be sure positive (+) must be connected to positive (+) and negative (-) must be connected to negative (-).

AC Input/Output Connection

Caution!! Before connecting AC input power source, please install a separate AC breaker between inverter and AC input power source. This will ensure the inverter can be safely disconnected during maintenance and fully protected from over current of AC input. The recommended AC breaker is 30A for both APS1000-12 and APS2000-24 models.

Caution!! Please don't connect the output AC to "Grid" terminals nor connect the grid to the "Load" terminals. Doing so will permanently damage inverter.

WARNING! All wiring must be performed by a qualify person.

WARNING! It's very important for system safety and efficiency operation to use appropriate cable for Grid connection. To reduce risk of injury, please use the recommended proper cable size as below.

AC Wiring

We recommend using 12AWG wire to the AC terminal block. If the inverter is installed farther than 70 feet from main power source, wire gauge must be sized properly to avoid big voltage drops. Be sure all wiring is UL compliant, call our tech support if you are not sure how to wire any part of the inverter.

WARNING! It's very important to do the wiring correctly on battery terminals and high voltage AC side.

Suggested cable requirement for AC wires

Model	Gauge	Torque Value
APS1000-12 APS2000-24	12AWG	1.2~1.6Nm

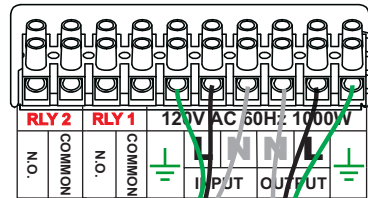

➡➡
AC INPUT

➡➡
AC OUTPUT

AC Wiring (120VAC, Single phase, 60Hz)
Input: Ground +Hot line +Neutral (Main Source)
Output: Neutral +Hot line +Ground (Load)

Please follow these steps to connect inverter to Load/Grid:

1. Before making Load/Grid connection, be sure to open DC protector/breaker first.
2. Strip each individual wire/conductor about 3/8".
3. Connect grid wires according to polarity indicated on terminal block and tighten the terminal screws. Be sure to connect protective earth conductor (⊕) first.

⊕-> Ground (green)
 L-> LINE (black)
 N-> Neutral (white)

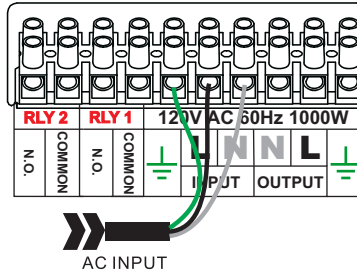

	<p>WARNING: Be sure that AC power source is disconnected before attempting to hardwire it to the unit.</p>
--	--

4. Then, connect Load (output) wires according to polarity indicated on terminal block and tighten terminal screws. Be sure to connect protective earth conductor (⊕) first.

⊕-> Ground (green)
 L-> LINE (black)
 N-> Neutral (white)

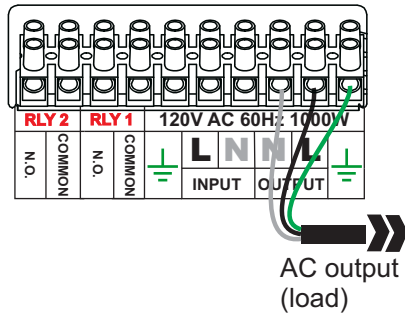

5. Make sure all wires are securely connected.

<p>CAUTION: Appliances such as air conditioner require at least 2~3 minutes to restart to have enough time to balance refrigerant gas inside of circuits. If a power outage occurs and recovers in a short time, it will cause damage to your connected appliance. To prevent this kind of damage, please check manufacturer of air conditioner if it's equipped with time-delay function before installation. Otherwise, this inverter will trigger overload fault and cut off output to protect your appliance but it is still possible it will cause internal damage to the air conditioner.</p>
--

Electrical Performance

<i>Line Mode Specifications:</i>		
MODEL	Model	
	APS1000-12	APS2000-24
Input Voltage Waveform	Sinusoidal (utility or generator)	
Nominal Input Voltage	120Vac	
Low Line Disconnect	75Vac \pm 2%	
Low Line Re-connect	80Vac \pm 2%	
High Line Disconnect	140Vac \pm 2%	
High Line Re-connect	135Vac \pm 2%	
Max AC Input Voltage	140Vrms	
Nominal Input Frequency	50Hz/ 60Hz (Auto detection)	
Low Line Frequency Re-connect	44 \pm 0.3Hz for 50Hz;	
Low Line Frequency Disconnect	40 \pm 0.3Hz for 50Hz;	
High Line Frequency Re-connect	75 \pm 0.3Hz for 50Hz;	
High Line Frequency Disconnect	80 \pm 0.3Hz for 50Hz;	
Output Voltage Waveform	Same as Input Waveform	
Over-Load Protection (SMPS load)	Circuit breaker	
Output Short Circuit Protection	Circuit breaker	
Efficiency (Line Mode)	>95%	
Transfer Time (Ac to Dc)	10ms (typical)	
Transfer Time (Dc to Ac)	10ms (typical)	
Pass through without Battery	Yes	
Max Bypass Overload Current	30A	40A

Inverter Mode Specifications:

MODEL	Model	
	APS1000-12	APS2000-24
Output Voltage Waveform	Pure Sine wave	
Rated Output Power (VA)	1000	2000
Rated Output Power (W)	1000	2000
Power Factor	1.0	
Nominal Output Voltage (V)	120VAC	
Nominal Output Frequency (Hz)	60Hz \pm 0.3Hz / 50Hz \pm 0.3Hz	
Auto tracking Main Frequency (Hz)	Yes (Following Main first connection) 50Hz @40-80Hz 60Hz @40-80Hz	
Output Voltage Regulation	\pm 10% rms	
Nominal Efficiency	>80%	
Over-Load Protection (SMPS load)	(110%<load<125%) \pm 10%: Fault (shutdown output) after 2minutes; (125%<load<150%) \pm 10%: Fault (shutdown output) after 20s; Load>150% \pm 10%: Fault (shutdown output) after 2s	
Surge rating	2,000VA	4,000VA
Capable of starting electric motor	Instant Reverse Gate Motors Two 1/2 HP or One 1HP	Instant Reverse Gate Motors Four 1/2 HP or Two 1HP
Output Short Circuit Protection	Current limit (Fault after 10s)	
Nominal DC Input Voltage	12V	24V
Min DC start voltage	11V	22V
Low Battery Alarm	11Vdc \pm 0.3Vdc	22Vdc \pm 0.6Vdc
Low DC input Shut-down	10.5Vdc \pm 0.3Vdc	21Vdc \pm 0.6Vdc
High DC input Alarm & Fault	16Vdc \pm 0.3Vdc	32Vdc \pm 0.6Vdc
High DC input Recovery	15.5Vdc \pm 0.3Vdc	31Vdc \pm 0.6Vdc
Power saver	Load \cong 25W	

Charge Mode Specifications:

MODEL	Model	
	APS1000-12	APS2000-24
Nominal Input Voltage	120Vac	
Input Voltage Range	75-140Vac	
Nominal Output Voltage	Same as input voltage	
MAX Charge Current	35A	
Charge Current Regulation	Charge current adjustable: 25%, 50%, 75%, 100%. (Optional)	
Battery initial voltage	10.5-15.7Vdc	21V-31.4Vdc
Charger Short Circuit Protection	Circuit breaker	
Breaker Size	40A	
Over Charge Protection	≥15.7Vdc	≥31.4Vdc
	Alarm beeps 0.5s second & Fault after 60s	

Charge Algorithm

Algorithm	<p>Three stage: Boost CC (constant current stage) → Boost CV (constant voltage stage) → Float (constant voltage stage)</p>
Charge Stage Transition Definitions	<ul style="list-style-type: none"> ◆ Boost CC Stage: If A/C input is applied, the charger will run at full current in CC mode until the charger reaches the boost voltage. ◆ Software timer will measure the time from A/C start until the battery charger reaches 0.3V below the boost voltage, then take this time as T_0 and $T_0 \times 10 = T_1$. ◆ Boost CV Stage: Start a T_1 timer; the charger will keep the boost voltage in Boost CV mode until the T_1 timer has run out. Then drop the voltage down to the float voltage. The timer has a minimum time of 1 hour and a maximum time of 12 hours. ◆ Float Stage: In float mode, the voltage will stay at the float voltage. ◆ If the A/C is reconnected or the battery voltage drops below 12Vdc/24Vdc, the charger will reset the cycle above. ◆ If the charge maintains the float state for 10 days, the charger will reset the cycle. <p style="text-align: center;">ADJUSTABLE TIME DEPENDING ON BATTERY BANK SIZE</p> <p>FOR 24 VOLTS X 2</p> <p>THE NEW BATTERY CHARGERS AND BOOSTERS OFFER THE FASTEST CHARGE RATE CURRENTLY AVAILABLE. STEP 1 - CONSTANT CURRENT CHARGE STEP 2 - ABSORPTION CHARGE AT 14.4/14.5 V STEP 3 - LOW VOLTAGE RESET TO STEP 1</p>

LCD Display Icons

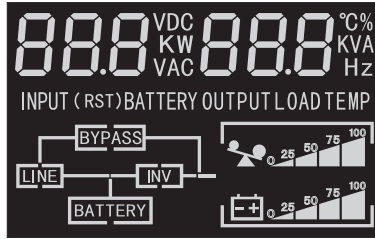

Icon	Function description
UPS input / output parameters Information	
	<ol style="list-style-type: none"> 1. Indicate input voltage, input frequency, battery voltage and charger current 2. Indicate output voltage, output frequency, load in VA, load in W.
UPS Work Status Information	
	UPS work status display, output and bypass mains electricity charge, the inverter output of the inverter power saving mode status display.
Load Information	
	Indicates load level by 0-24%, 25-49%, 50-74% and 75-100% in battery mode and charging status in line mode.
Battery Information	
	Indicates battery level by 0-24%, 25-49%, 50-74% and 75-100% in battery mode and charging status in line mode.

Line Mode

When utility is the unit the battery from the utility, LCD indicate charge current:

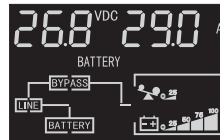
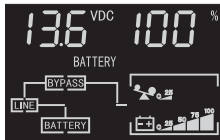

In utility mode the unit provide output power from the utility, the indication and displays are following figures:

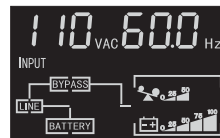

Battery Mode

In battery mode the unit will provide output power from battery or PV, LCD indicate battery capacity :

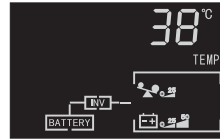
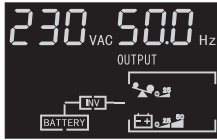

Fault Mode

When inverter fault, the indication and displays are as following figures:

- 1: fan jam
- 2: overload
- 3/6/7: output short circuit
- 4: over temperature
- 8/9: battery overvoltage.

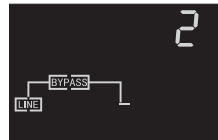

Auto generator start (AGS)

There is an extra connector in front of the inverter (**Relay 2**) used to start a generator or to trigger a gate operator to open the gate before battery runs out of power. If the utility power is abnormal and single battery discharges below 11VDC, the inverter will send out a signal to either a generator start circuit or to a gate operator to trigger the gate to open. Once the battery is charged to 13.5VDC or higher, the signal will deactivate and switch to normal operation.

Auto AC power off signal

Includes a relay N.O. contact used to trigger a gate operator to open the gate on AC utility power failure. Once AC utility power fails, the relay will trigger the signal.

Relay Function for gate operators:

RELAY 1: Activates immediately after a power outage. It can be to trigger a gate operator to open the gate. **One time open.** It will stay active until power is restored.

RELAY 2: Activates after a power failure and battery voltage has reached the low level threshold. It could be used to trigger a gate operator to open before battery is fully depleted.

Using this relay to trigger a gate to open, will allow a gate operator to run on battery backup but will ensure gate opens before battery fails.

For Failsafe connect to gate operator **OPEN_CMD**

For Failsecure connect to gate operator **CLOSE_CMD**

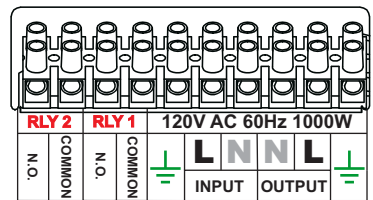

BTS	Battery temperature sensor (optional)	Variances in charging voltage & S.D. voltage base on the battery temperature.
-----	---------------------------------------	---

Setting Sine

On the rear panel of inverter, there are 5 DIP switches which enable users to customize the performance of the device.

Table dip switch function setting

DIP switch NO.	Switch function		Position :1	Position : 0
SW1	Low battery trip volt		10.5VDC	11.0VDC
			*2 for APS2000-24	
SW2	AC input range / (AVR)	120VAC	75-140VAC	95-140VAC
SW3	Power saver auto setting		check load every 5s	check load every 30s
SW4	O/P frequency setting		50Hz	60Hz
SW5	Battery/AC priority setting		Utility priority	Battery priority

SW1 : Low battery trip volt:

For APS1000-12, the low battery trip volt is set at 11.0VDC for sealed lead acid battery. It can be changed to 10.5VDC using Sw1 for deep cycle lead acid battery, this is to prevent batteries from over-discharging while there is only a small load applied on the inverter. (*2 for APS2000-24)

SW2: AC input range:

There are different acceptable AC voltage input ranges for different kinds of loads. For some relatively sensitive electronic devices, a narrow input range of 95-140 VAC is required to protect them.

While for some resistive loads which work in a wide voltage range, the input AC range can be customized to 75-140VAC, this helps to power loads with the most AC input power without switching to battery bank. For **gate operators** we use the setting **75-140VAC**

SW3: Power saver auto setting:

By default the inverter is set to detect the load for 250ms every 5 seconds. This cycle can be customized to 30 seconds through the Sw3 DIP switch. Note: Power saver mode should not be used when using inverter for a gate operator.

SW4: O/P frequency setting:

Set the inverter frequency while in battery mode.

SW5: Solar/AC priority:

The inverter is designed with AC priority by default. This means, when AC input is present, the battery will be charged first, and the inverter will transfer the input AC to power the load. Only when AC input is stable for a continuous period of 15 days, the inverter will start a battery inverting cycle to protect the battery. After 1 cycle normal charging and AC will be restored and go back to bypass mode.

The AC priority and battery priority switch is SW5. When switch is set to battery priority, the inverter will run on battery power even if AC input is present. Only when the battery voltage reaches the low voltage threshold (11.5V for 12V & 23V for 24V). The inverter transfers to AC input, charges battery, and switches back to battery when it is fully charged. This function is mainly for wind/solar applications and utility power is strictly backup. But it could also be useful in locations where a lot of **brow-outs** happen.

Other features

Battery voltage restart

After low battery voltage shut off (10.5V for 12V model / 20V for 24V model), the inverter is able to restore operation after the battery recovers to 13V for 12V model and 26V for 24V model (with power switch still in the “ON” position). This function helps to save the users extra work reactivating the inverter when the low battery voltage returns to an acceptable range in the renewable energy systems. the built in battery charger will automatically reactivate as soon as utility/generator ac has been stable for 15 seconds.

Important:

	Switch setting	Description	Boost		Float	
			Voltage		Voltage	
			APS1000-12/APS2000-24		APS1000-12/APS2000-24	
Battery Type Setting  BATTERY TYPE SELECTOR	0	Battery prefer mode	Low trip to AC model 11.5V/23V		High trip to battery 14V/28V	
	1	Gel USA	14V/28V		13.4V/27.4V	
	2	AGM 1	14.1V/28.2V		13.4V/26.8V	
	3	AGM 2	14.6V/29.2V		13.7V/27.4V	
	4	Sealed lead acid	14.4V/28.8V		13.6V/27.2V	
	5	Gel EURO	14.4V/28.8V		13.8V/27.6V	
		Open lead acid	14.8V/29.6V		13.3V/26.6V	
	7	Calcium	15.1V/30.2V		13.6V/27.2V	
		De sulphation	15.5V/31V		4 hours then off	
	9	Not used	-	-	-	-

Note: APS series inverter include Sealed Lead Acid Batteries. If different chemistry batteries are used, this setting must be adjusted to match the charging voltage appropriate for the type of battery.

Fault recovery	By restarting the inverter. Turn it OFF and back ON.
-----------------------	--

FAN Operation

Variable speed fan operation is required in invert and charge mode. This is to be implemented in such a way as to ensure high reliability and safe unit and component operating temperatures in an operating ambient temperature up to 50°C.

- Speed to be controlled in a smooth manner as a function of internal temperature and/or current.
- Fan should not start/stop suddenly.
- Fan should run at minimum speed needed to cool unit.
- Fan noise level target <60db.

The fan logic as below:

Condition	Enter condition	Leave condition	Speed
HEAT SINK TEMPERATURE	$T \leq 45^{\circ}\text{C}$	$T > 51^{\circ}\text{C}$	20%
	$51^{\circ}\text{C} \leq T < 68^{\circ}\text{C}$	$T \leq 60^{\circ}\text{C}$ or $T \geq 68^{\circ}\text{C}$	40%
	$T > 68^{\circ}\text{C}$		100%
Load% (Invert mode)	$0\% \leq \text{Load} < 50\%$	$\text{Load} \geq 50\%$	20%
	$\text{Load} \geq 50\%$	$\text{Load} \leq 40\%$ or $\text{Load} \geq 80\%$	80%
	$\text{Load} \geq 80\%$	$\text{Load} \leq 75\%$	100%

Warning code/Audible Alarm

Status	Item	Indicators on display panel				Buzzer
		CHARGE	LINE	INVERTER	FAULT	
Line Mode	CC	√	√	x	x	—
	CV	blink	√	x	x	—
	Float	blink	√	x	x	—
	Standby	x	√	x	x	—
Invert Mode	Inverter on (Power saver off)	x	x	√	x	—
	Power saver on	x	x	blink	x	—
Alarm Mode	Battery Low	x	x	√	x	beep 0.5s every 5s
	Battery High	x	x	√	x	beep 0.5s every 1s
	Overload on invert mode	x	x	√	x	Refer to “Audible alarm”
	OverTemp on invert mode	x	x	√	x	beep 0.5s every 1s
	OverTemp on line mode	√	√	x	x	beep 0.5s every 1s
	Over charge	√	√	x	x	beep 0.5s every 1s
Fault Mode	Fan lock	x	x	x	√	beep continuous
	Battery High	x	x	x	√	beep continuous
	Inverter mode overload	x	x	x	√	beep continuous
	OverTemp	x	x	x	√	beep continuous
	Over charge	x	x	x	√	beep continuous
	Back Feed Short	x	x	x	√	beep continuous

Note: √ = indicator ON. x = indicator OFF. √, blink shows the indicator blinking about 0.5s on and 0.5s off.

Troubleshooting Guide

Troubleshooting contains information about how to troubleshoot possible error conditions while using the APS series inverter with Charger.

The following chart is designed to help you quickly pinpoint the most common inverter failures.

Problem	Possible cause	Solution
battery lowvoltage	Battery discharged	continue to charge battery full
	Battery down to or below 10V while main switched off, then battery is damaged.	change battery
battery overvoltage	charger fault/battery connection fault	check charger, and check and make sure battery connection is correct
overload	too many devices connected	turned off inverter,remove some loads
	connected motor's current draw exceeds inverter power	motor current draw at start is huge, 3-4 times. you need inverter with higher wattage
over temperature	There isn't enough ventilation to cool the inverter.	keep batteries separated from eachother Check if fan is working normally
	inverter overload	remove some loads
over charge	charger fault/charger battery select switch in wrong battery setting	set the "battery select" switch to correct battery setting
no output voltage	power switch in wrong position	set power switch to power ON (down position)
	wire connections are incorrect	Check if LED lights are correct to make sure the wire connection inside is OK.
	inverter is damaged	open machine case to check components
not charging	inverter battery selector in wrong setting	select the correct battery chemistry
	wire connections are incorrect	Check if LED lights are correct to make sure the wire connection inside is OK
	inverter is not in AC mains mode	turn ON AC mains to switch to AC mode
load light flashing	panel switch is on power saver "ON"	turn panel switch to power "ON" (down position)
fan stopped running	Fan blocked	check if something is blocking the fan
	Fan is jammed	Open the inverter and find a white prove cable (on cooling fan). Keep it at short-circuit, the fan should run. If not, then there's a problem with the fan.
Output short circuit	Load at short circuit	Check load carefully
	Mosfet broken	Check inside inverter
Note: APS1000-12 and APS2000-24 inverter's fan starts to run when temperatures reach 122-140° F		
Need any support,contact our customer service		



Power Door Products

(914) 698-5083

www.PowerDoorProducts.com

USER'S MANUAL
POWER INVERTER